

POWERGEAR *Miniature* **NEW**

Impressively small and incredibly powerful.

Actual Size



*The bevel gearbox with minimum size
at maximum performance and precision*

The Revolution among Miniature Gears.

POWERGEAR^{Miniature}

Forget everything you know about miniature gears. Dimensions, weight, precision – the new PowerGear Miniature sets new standards.

PowerGear Miniature has a sensationally small installation size, an extremely light-weight aluminium housing, maximum performance and precision as well as many other advantages. The unique design of PowerGear Miniature will open up a vast range of applications in drive technology.

- miniature gear for maximum precision
- low backlash and high transmission accuracy
- case-hardened bevel gear tooth system
- friction-locked shaft-and-bevel-gear fit
- energy-efficient through high level of efficiency of 98%
- extremely light-weight aluminium housing
- maintenance free through synthetic oil

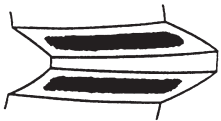

Optimised contact pattern for uniform gear load

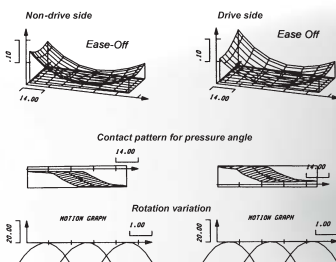

Optimised Gleason gearing for highest speeds

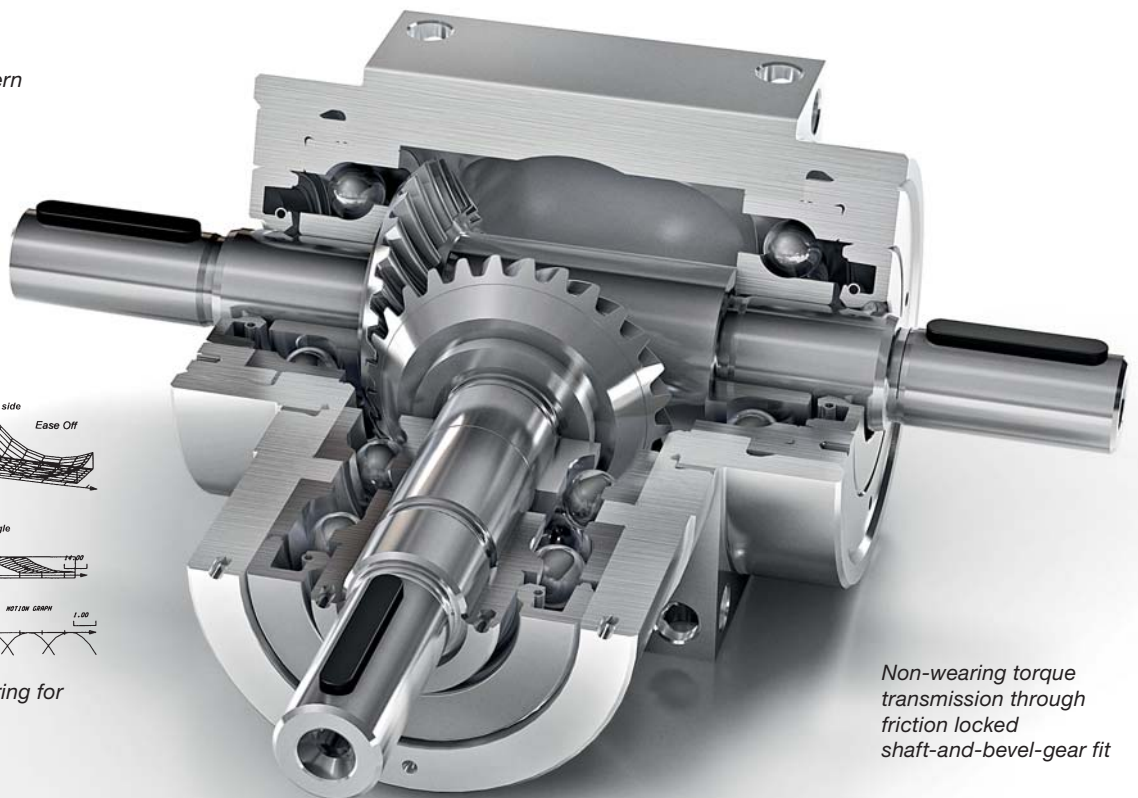

Non-wearing torque transmission through friction locked shaft-and-bevel-gear fit

Options:

- Special adjustments and customised designs

Performance table

		Abbreviation	Unit	P27	P33	P45
Output torque						
Nominal torque	i=1.0:1	T _{2N}	Nm	3.5	5	16
maximum acceleration ①		T _{2B}	Nm	5	7.5	25
EMERGENCY STOP torque ②		T _{2Not}	Nm	7	10	32
Nominal torque	i=1.5:1	T _{2N}	Nm	2.2	3.2	11
maximum acceleration ①		T _{2B}	Nm	3.3	4.8	16.5
EMERGENCY STOP torque ②		T _{2Not}	Nm	4.4	6.4	22
Nominal torque	i=2.0:1	T _{2N}	Nm		2.3	8.5
maximum acceleration ①		T _{2B}	Nm		3.5	13
EMERGENCY STOP torque ②		T _{2Not}	Nm		4.6	17
Nominal torque	i=3.0:1	T _{2N}	Nm		1.5	6.5
maximum acceleration ①		T _{2B}	Nm		2	10
EMERGENCY STOP torque ②		T _{2Not}	Nm		3	13
Nominal torque	i=4.0:1	T _{2N}	Nm		1.3	5
maximum acceleration ①		T _{2B}	Nm		2	7.5
EMERGENCY STOP torque ②		T _{2Not}	Nm		2.6	10
Input speed	i=1.0:1	n _{1max} ③	min ⁻¹	7500	7500	7500
Output backlash ④	nominal	j _t	arcmin	≤15	≤15	≤15
Permissible radial load ⑤		F _{1Rmax}	N	120	160	320
		F _{2Rmax}	N	150	200	400
Permissible axial load ⑤		F _{1Amax}	N	60	80	160
		F _{2Amax}	N	75	100	200
Efficiency at max load		η	%	>98	>98	>98
Running noise at 1500 min ⁻¹		L _{pA}	db(A)	≤70	≤70	≤70
Weight		m	kg	0.16	0.22	0.55
Service life		L _h	h	>15000	>15000	>15000
Lubrication	synthetic oil, ISO VG 150					
Average oil quantity			ml	8	13	35
Operating temperature			°C	≤ 80 °C	≤ 80 °C	≤ 80 °C
Paint	unpainted					

Ex-Protection: Ex II 2 D/G c T4 Type of protection: IP 64

① at max 1000 cycles per hour, otherwise please contact us

② permissible max 1000 times during the service life of the gearbox

③ follow permissible operating temperatures

④ Assuming 2% load at the output

⑤ Point of force application is center of shaft at an output speed of n = 400 min⁻¹

Shaft arrangements

each right view = mirrored illustration

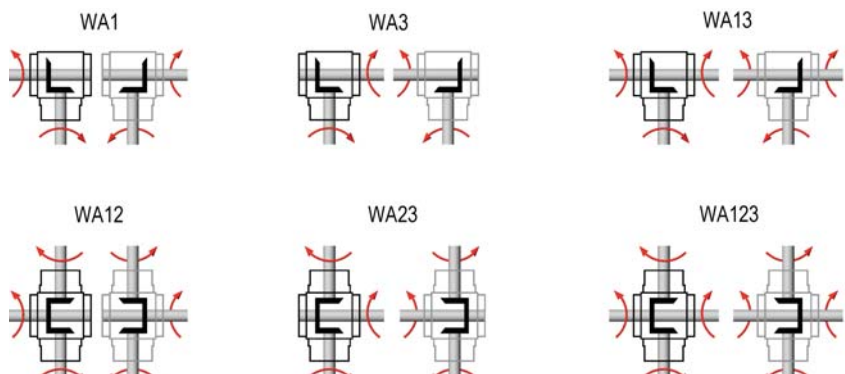

Dimensions Configuration L

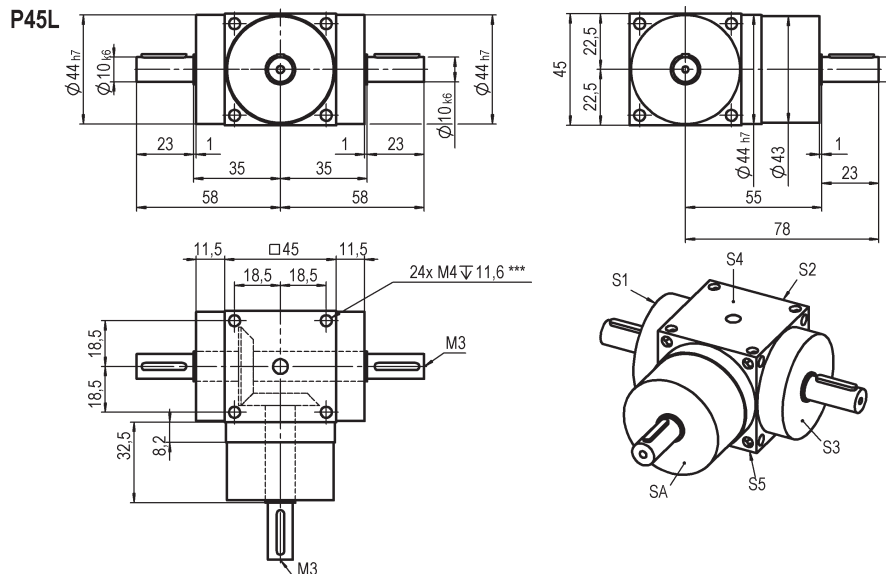
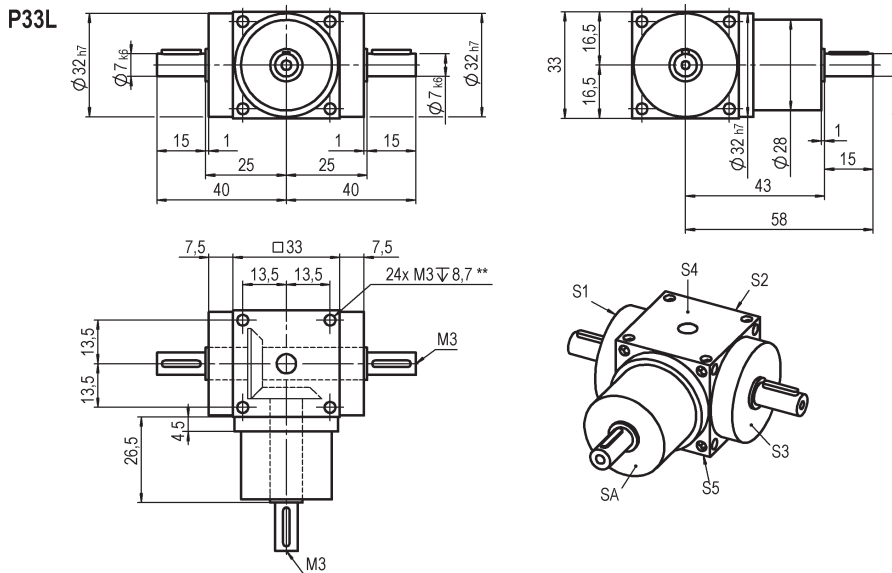
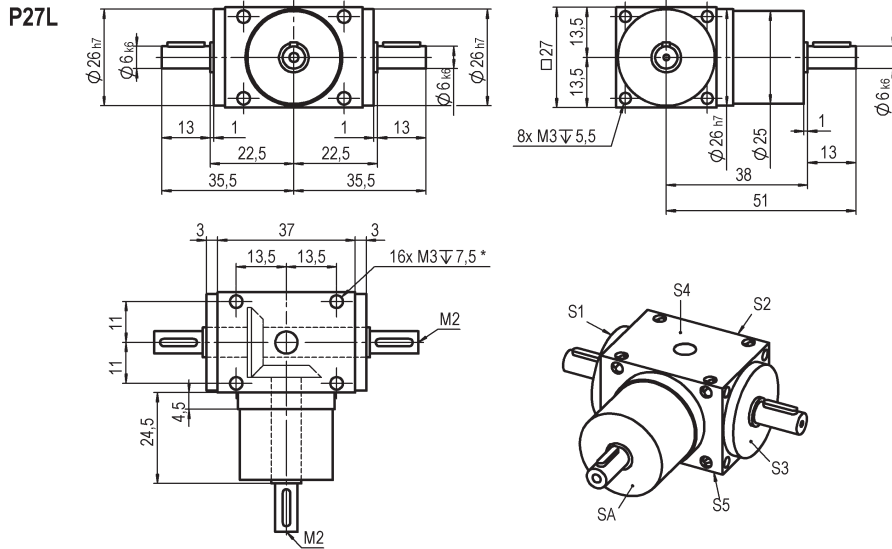

*) thread starts from 4 mm depth, **) thread starts from 4.5 mm depth, ***) thread starts from 6 mm depth, feather key to DIN 6885/1

Customised Solutions for Miniature Gears

We offer a bespoke design, specially adapted to the customer's applications, with innovatively designed drive solutions also for the miniature sector. We are driven by the desire to support our customers in the new development and optimization of their tooth system designs through the innovative and sustainable development of special gearboxes.

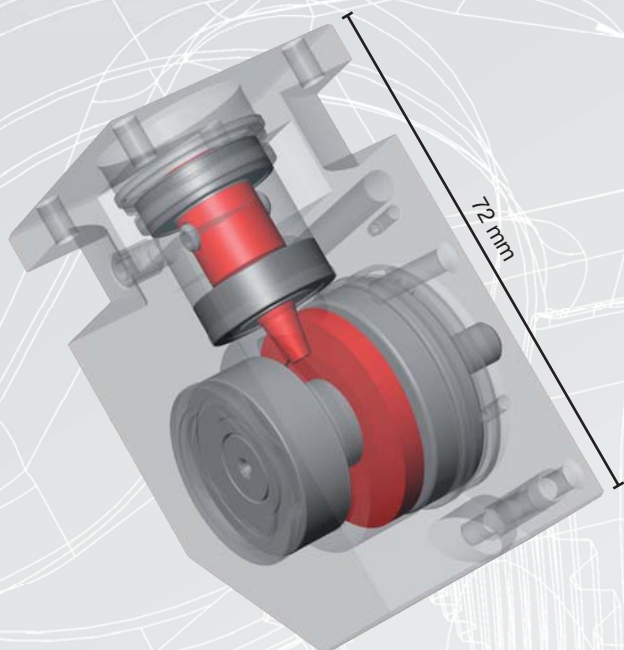

High transmission miniature gearbox $i = 12:1$ for applications in the automotive industry and in medical technology.



The smaller the bevel gear, the greater the expertise necessary.

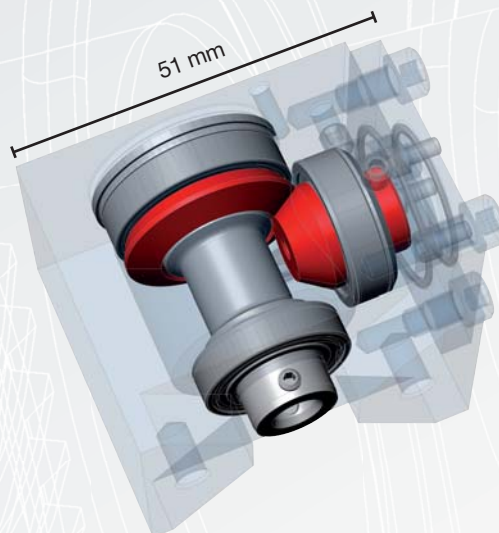

Customised miniature gearbox $i = 2:1$ for applications in the packaging industry.

Please note that,

all information contained in this catalogue is provided without guarantee and is not binding. In particular, dimensions and values only provide guidance. Any exact, specific requirements must be agreed with us. Specifications and features listed in the catalogue are subject to a written contract.

BEVEL GEAR

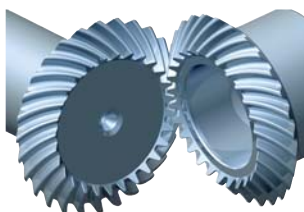

Spiral, Hypoid and Zerol Bevel Gears

- Standard range of products and custom-made versions
- Module ms from 0.5 to 12
- Diameters up to 410 mm
- Shaft angles from 10° to 170°
- More than 60 years of experience
- In-house gearing calculations
- We manufacture to your drawing or advise you of possible alternatives
- Milled or ground gear tooth cutting

POWER GEAR



The high performance bevel gearbox

- High torque, small size
- For highest input speeds
- Ratios from $i = 1:1$ to $5:1$
- Torques up to 7000 Nm
- Output via solid and hollow shaft
- Motor mounting either directly or via coupling and lantern
- Variable ratios and uniform dimensions

DYNA GEAR



The highly dynamic servo right angle gearbox

- Hypoid gearing
- High input speeds at medium to high torques
- Ratios **single-stage**
 $i = 3:1$ to $30:1$
- Ratios, two-stage, up to $150:1$
- Torques up to 1440 Nm
- Flexible motor mounting via coupling and lantern
- Low backlash ≤ 2 arcmin
- Variable ratios and uniform dimensions

DYNA GEAR^{Economy}

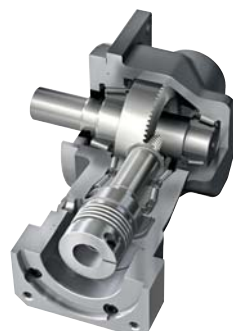

The cost-effective servo right angle gearbox

- Hypoid gearing
- High input speeds at medium torques
- Ratios **single-stage**
 $i = 5:1, 8:1, 10:1$ and $15:1$
- Torques up to 260 Nm
- Flexible motor mounting via coupling and flange
- Backlash ≤ 6 arcmin
- Variable ratios and uniform dimensions

DESIGN GEAR



The customised gearbox

- Single-stage gearbox available as gear-change or reversing gearbox
- Forced oil circulation lubrication system gearbox for high speeds and torques
- Labyrinth sealed gearbox with an efficiency of $> 99\%$
- Special gearbox with additional functional elements
- Endless possibilities on request

KS TWIN GEAR

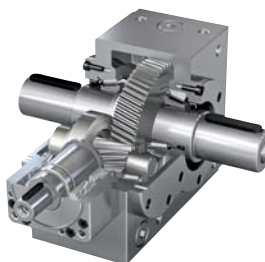

The bevel helical gearbox

- Two-stage bevel helical gearbox with ratios of up to $75:1$
- Torques up to 7500 Nm
- Torsional backlash < 6 arcmin
- Compact design
- Motor mounting either directly or via coupling and lantern
- High torsional stiffness
- High input speeds at high torques