

**Metal Bellows Coupling**

axial pluggable, with expanding clamps

optional  
laserwelded  
optional full stainless  
steel version

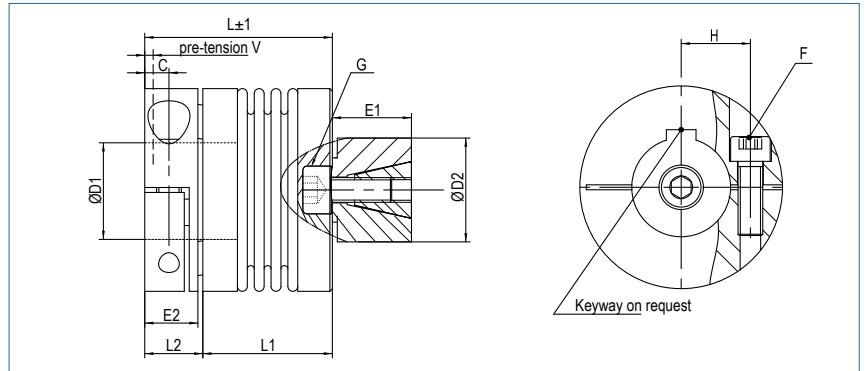

**Order Code**

**KB8P / 60 - 78 - 15 - 30 - D - (S)**

Type / Size                      Length L                      ØD1 (H7)                      ØD2 (f7)                      Plug System                      Options

Size	Torque TKN (Nm)	Dimensions (mm)									Technical Data								
		L Length	Ø A Outer Ø	D1 Bore Size (H7) min-max	D2 (f7) min-max	H	C	E2	E1	F/G Screw (ISO4762) TA (Nm)	Mass (kg)	Moment of Inertia J (g m²)	Spring Stiffness			Misalignment			max. speed (min-1)
												torsional CT 10³ (Nm/rad)	radial CR (N/mm)	axial CA (N/mm)	radial ΔKr (mm)	axial ΔKa (mm)	angular ΔKw (°)		
18	18	52	45	10-24	13-25	17	5.5	12	20	M5	0.18	0.04	20	205	50	0.2	0.5	1.5	12800
		60								8	0.19	0.05	15	82	36	0.25	0.5	2	12800
30	30	59.5	56	10 32	14-30	20	7.3	17	25	M6	0.33	0.15	38	720	50	0.15	0.6	1.5	10300
		67.5		#30						15	0.34	0.16	28	225	28	0.25	1.0	2	10300
60	60	68	66	12-35	23-38	23	8.6	21	27	M8	0.49	0.28	75	1150	90	0.15	0.6	1.5	8700
		78								40	0.51	0.31	50	340	50	0.25	1.0	2	8700
150	150	75	82	14-44	26-42	28	9.8	21.5	32	M10	0.87	0.90	155	2020	145	0.2	0.5	1.5	6900
		87								84	0.92	0.95	105	595	85	0.25	0.8	2	6900
300	300	93	110	20-60	38-60	39	10.8	27	45	M12	1.87	3.28	502	6300	280	0.2	0.5	1.5	6000
		107								145	1.91	3.37	285	1400	145	0.25	0.8	2	6000

**Material** bellows - stainless steel  
collet clamps - aluminium  
expanding clamps - steel

**Hub** bore tolerance: H7

**Temperature Range** -30 °C ~ 120 °C

**Keyway** optional acc. DIN 6885  
biggest bore marked with a #

